

# OEM Paint Shop, Trim, and Final Assembly **ADHESIVE & SEALANT** Selection Guide

*Applications, Products, Material  
Considerations, Testing & Specifications*



Brought to you by:

**ASC**

THE ADHESIVE AND SEALANT COUNCIL  
SECURING THE FUTURE®

# About the Guide

## SCOPE AND PURPOSE

This guide educates the reader about the typical applications of adhesives and sealants in automotive and heavy truck paint and assembly shops. It is an extension of the [ASC OEM Body Shop Adhesive and Sealant Selection Guide](#) picking up the process as the body-in-white (BIW) is processed through prime and enters the main paint shop processes. The process continues through paint, trim and final assembly. This guide does not cover chassis, powertrain, or electrical applications. Repair and aftermarket (after sale) applications may be referenced but are not covered comprehensively. Typical applications that are at lower-tier suppliers are not covered unless there may be a significant cross-over to the OEM (original equipment manufacturer).

*Published: October 2018*

*Cover photos source: Henkel, BMW, Volkswagen*





## DISCLAIMER

The guide is intended to be an informative resource for a wide variety of adhesive bonding applications in automotive and heavy truck OEM paint, trim and assembly shops. It is not intended to be a guideline for best practices or an instructive manual for design, engineering, or manufacturing. The content reflects contributions from current member companies of the Adhesive and Sealant Council at the time of publication and does not discuss applications of adhesives and sealants that are under development. For more detailed information, contact your adhesive or sealant supplier, or identify a supplier by using the ASC Vendor Select Tool. The ASC Vendor Select Tool is a quick and efficient way for a user to find an adhesive or sealant chemistry that is used in a market segment for finished goods. The tool is located on [www.adhesives.org](http://www.adhesives.org) and can also be used to find typical raw material types or equipment. The Vendor Select Tool direct link to manufacturer's websites can be viewed using this link or by selecting the desired sub-segment of passenger cars and trucks or trucks and busses. Additional resources on adhesives and sealants in automotive and heavy trucks follow.

*Resources for individuals seeking information on adhesives and sealant in automotive and heavy trucks (links):*

- [Cars, Trucks, and Buses Industry Page on Adhesives.org](#)

*Selection Guides:*

- [OEM Body Shop Adhesive & Sealant Selection Guide](#)
- [OEM Paint Shop, Trim & Final Assembly Adhesive & Sealant Selection Guide](#)

*ASC Whitepapers & Presentations:*

- [Adhesives & Sealants as an Enabling Technology for Lightweight, Safe, and High Performing Steel Vehicles](#)
- [Adhesives & Joining Methods in Land Transportation](#)
- [Adhesive Opportunities & Outlook in Light Vehicles](#)
- [Adhesive Opportunities & Outlook in Heavy Duty Trucks & Buses](#)

*Adhesive & Sealant Sourcing Tool:*

- [ASC Buyer's Marketplace](#)



# ASC Growth Task Force

ASC would like to thank the following ASC member companies that have contributed time, figures, information, charts, pictures, and content for this guide.

## CONTRIBUTING COMPANIES



GUIDE BY:





# Contents

<b>Introduction</b> .....	7
<b>Paint Shop Adhesives and Sealants</b> .....	8
<b>Sealing</b> .....	8
Automotive OEM .....	8
Transportation: Non-Automotive – Commercial Vehicle .....	11
Test and Validation .....	13
<b>Adhesives</b> .....	15
Post-Prime – Pre-Topcoat Structural Bonding .....	15
Other Materials and Applications .....	16
<b>Body Trim and Final Assembly</b> .....	21
Pressure Sensitive Adhesives .....	22
Corrosion Control .....	26
Body Trim Assembly .....	27
Glazing - Glass Bonding .....	27
Transportation - Non-Automotive and Repair .....	30
Glass Bonding Test and Validation .....	31
<b>Adhesive and Sealant Joint Design Considerations</b> .....	32
<b>Auto &amp; Truck OEM Adhesive Testing &amp; Specifications</b> .....	34
<b>Conclusion</b> .....	36
<b>Suppliers and Manufacturers</b> .....	37
 <i>Special Sections:</i>	
NVH – Noise, Vibration and Harshness .....	19
Corrosion .....	26
Glazing Trends .....	28



*Figure 1: Car entering an automotive pre-treatment bath prior to ecoat. Car bodies are fully immersed in several wash, treatment, and rinsing baths before the adhesives and sealants applied in the body shop are cured in the e-coat oven. This is where the ASC Body Shop Guide Ends and where this guide picks up the process. Source: Henkel*



# Introduction

The ASC OEM Paint Shop, Trim, and Final Assembly Guide to Adhesives and Sealants Guide is an extension of the [ASC OEM Body Shop Adhesive and Sealant Selection Guide](#) picking up the process as the body-in-white (BIW) is processed through prime and enters the main paint shop processes (see Figure 1). While significant body structures are bonded and sealed in the body shop, important structural, sealing and performance systems and enhancements continue downstream in other shops. In many cases the adhesive and sealant applications may be performed in the OEM assembly process or in a sub tier supplied to the assembly plant finished ready for paint or finished to color.

This guide discusses the type and function of adhesives, sealants and related materials in the manufacture of vehicles in the transportation market. The guide further discusses typical test and development considerations for significant applications in these areas. All applications cannot be covered comprehensively within the scope of this document and should be further

addressed with the assistance of your materials suppliers.

Transportation – specifically ground transportation (not marine or aerospace) – defines the segment. Typical markets with common methods and materials include but are not limited to automotive and commercial vehicle (CV) usually defined as truck, bus, construction, agricultural equipment, trailers, and body builders. While industry commonly distinguishes between “Automotive OEM” and “Others” – the true distinction is “Volume” and “Capital.” By volume, we are simply distinguishing between high and low volume processes. Volume and vehicle application equally drive the selection of materials, tooling, and process. Whereas automotive OEM should be interpreted as a high-volume, highly capitalized process, non-automotive or commercial vehicle OEM applications are viewed as low volume, low capital processes.



# Paint Shop Adhesives and Sealants

## SEALING

### *Automotive OEM*

Paint shops curtail any activity that can damage or compromise the quality of the paint or finish, and/or generate dust or contamination in the shop environment. Sealing is deemed as a necessary process; its application is often scheduled by paint shops following the primary primer (e-coat or elpo -electro deposition primer) but before any additional primer, intermediate coat or top coat. Applying a sealant is recommended not only as a barrier to air and water but also for maintaining proper interior air pressure. Equally important, sealing is a necessary surface preparation step to bridge surfaces for painting.

Modern automotive body design minimizes

or eliminates the use of sharp edges and coach joints to avoid the Faraday Cage Effect. Coach joints are sheet metal panels that are bent 90° back from the surface and spot welded together leaving the sheet metal to dive away from the surface. Lap joints – which are two overlapping joints spot welded together – only exist on roof joints and non-primary cosmetic surfaces. Roof joints are covered by moldings. Sealing secondary cosmetic joints is required by most automotive OEM paint shops for sealing and enhanced aesthetics.

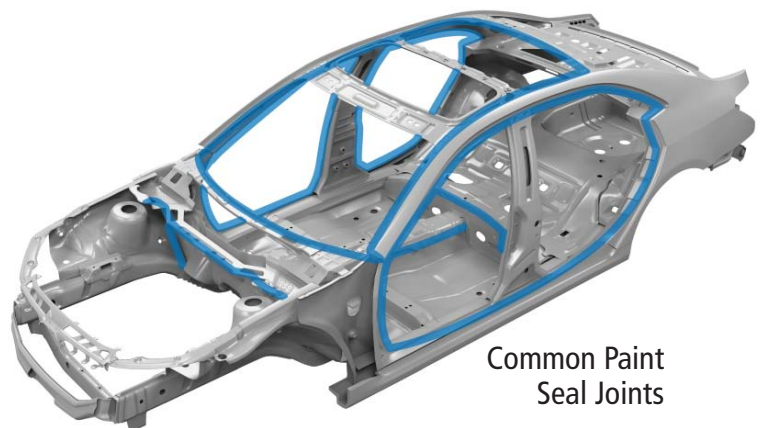

Common Paint Seal Joints

IN-DEPTH

### **Faraday Cage Effect**

Poor electrostatic paint coverage on sheet metal gaps or sharp edges can be attributed to the Faraday Cage Effect. The cause of and engineering solutions to remedy the Faraday Cage Effect are not well understood by coatings practitioners, according to Chris Lucy, Director, Application Engineering at CQTI. Applying an electrostatic coating to recessed areas or complex geometric shapes may lead to inadequate coating coverage due to the Faraday Cage Effect. Proper application of a paint sealer to smooth edge transitions or to fill joints will alleviate the coating issue and prevent thin coverage.

Plastisol sealants, which are extremely versatile in either a liquid or solid form, dominate in sealing applications. Plastisol sealer applications include exterior finished (cosmetic) joints; inner closures for seams and hems; interior body joints and seams; and underbody coatings for sealing, acoustic and stone chip.





Figure 2: Paint sealer applied to a test section. The plastisol is streamed/swirled across the joint applied by a robot. The joint would be a non-cosmetic and does not require tooling after application. Source: Henkel

Plastisols fill gaps and can be brushed or tooled as a smooth paint finish. Clean up is relatively easy without leaving a residue or film. Examples of the ease of application include either using a flexible squeegee – or using a small paper tube to “loom” (tool) the product for a clean finish (the excess sealant inside the tube is discarded). That said, design and automation in automotive plants has minimized the need for manual finishing; meaning, significantly less material is manually-applied and once applied is minimally manipulated due to automation, see Figures 2 and 3.

Over time, plastisols can gel in the container; to prevent this from happening, a well-designed pump and piping system

IN-DEPTH

### Plastisol Sealant

Consists of a PVC polymer powder blended with a plasticizer. Plastisols are, for lack of a better term, heat cured until the plasticizer is fully absorbed by the PVC to form a continuous solid mass. They can be cast, extruded, sprayed, streamed and swirled. Plastisols will clean easily from surfaces, as they do not cure until baked – and they have an excellent shelf life, with proper viscosity stability measures put into place.

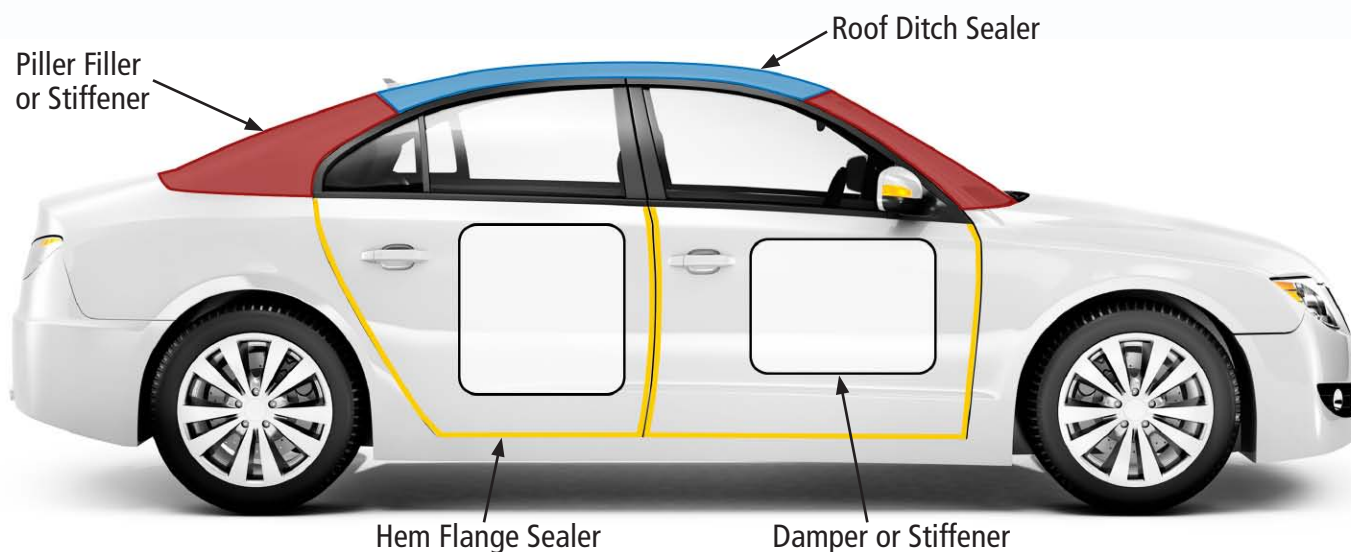

Figure 3: Common paint shop application areas. Seam seal around hem flange – the hem flange has a structural adhesive in the joint but requires further sealing for corrosion performance. The roof ditch joint can be sealed with sealer or tape. Pillars that do not have preform expandables are sealed with injectable urethane foam to block airflow and sound from the dash or rear areas. Door skins may be modified with a damper or stiffener to alter the skin properties.

**Primer Surfacer**

*A paint primer commonly used in automotive production as an intermediate primer between the electro deposition coating (ecoat) and the top coat (finish, color coating). This serves to improve surface finish and add an extra layer of UV (ultraviolet) protection to protect the ecoat from degradation.*

(which can reliably run in a manifold system for long intervals) commonly manages the continual flow of multiple application drops in the shop. Of course, like anything else, reliability has limitations, so care should be taken designing the piping system to avoid traps and dead spots and to provide for clean-out ports during maintenance.

If necessity is the mother of invention, then not unexpectedly the threat of a pending outright ban of the most common polymer used in plastisol sealants – polyvinyl chloride (PVC) – served as a strong impetus for development and the eventual adoption of acrylic sealants by paint shops. In recent years, PVC's status as a regulatory target has reversed. Therefore, PVC has reclaimed its place as the material of choice for plastisol sealants. Which, for paint shops, is clearly an advantage, given PVC plastisol sealants' unique versatility compared with alternatives. Plastisols can be compounded to have a consistency ranging from a fluid, self-leveling sealant to a solid, thumbable putty (with additional compounding

it'll achieve higher strength, better flow characteristics or lower cost).

A primer surfacer is often used over the e-coat primer to improve the quality of the finish and to provide additional UV (ultraviolet light) protection for the e-coat epoxy primers. Albeit additional UV protection can be built into topcoat paints, so the primer is not always necessary. Using a primer-surfacer also facilitates the cure of other sealers, otherwise a dedicated oven can be used for curing, or sealers can be cured during the topcoat bake-cure.

The trend in automotive is towards lower weight and energy efficiency. Many automotive original equipment manufacturers (OEMs) have compounded sealants for lower mass to reduce the weight applied. Others have optimized applications to reduce the amount applied. The reduction in energy usage in the paint facility has led to the desire to apply 3-Wet Technology for sealer – primer-surfacer followed by the topcoat, cured using only one bake (the driver is that the minimum cure temperature of a sealer is usually over 120°C (248°F)).



## Transportation: Non-Automotive – Commercial Vehicle

Not all paint shops can use plastisols; they will if they can but often cure conditions eliminate that material choice. Alternates exist: urethanes, silane modified polymers (SMP/MSP), acrylics, epoxies, polyesters and various hybrids. These have limitations mainly associated with their reactive nature, as curing changes the rheology, making tooling and finishing more difficult in a production environment. That said, alternative materials may also have superior material characteristics that are necessary for some applications. The improved properties can include toughness/elasticity, strength, thermal stability, and durability in severe conditions, depending on the material.

### IN-DEPTH

#### **1K Urethane Adhesive/Sealant**

*One-part moisture cure polyurethanes are one of the most widely used adhesive/sealants in the commercial vehicle industry for trim shop applications. 1K polyurethanes are ideal for customers who are seeking a low-cost elastomeric bond and/or a general-purpose seal. Elastomeric bonding is typically required when the bond joint experiences either high movement or high impact, or contains dissimilar substrates that are exposed to thermal cycling. See Figure 4 on next page for a comparison of curing mechanisms.*



## Two Cure Methods for Elastomeric Adhesives and Sealants

Figure 4: Comparison of 1k moisture curing with conventional 2k mixed systems. Moisture curing using the available atmospheric moisture to react from the outside to the inside. 2k systems are mixed and cure uniformly. 1k heat cured adhesives act like 2k system except inhibited until sufficient heat is applied. Source Henkel

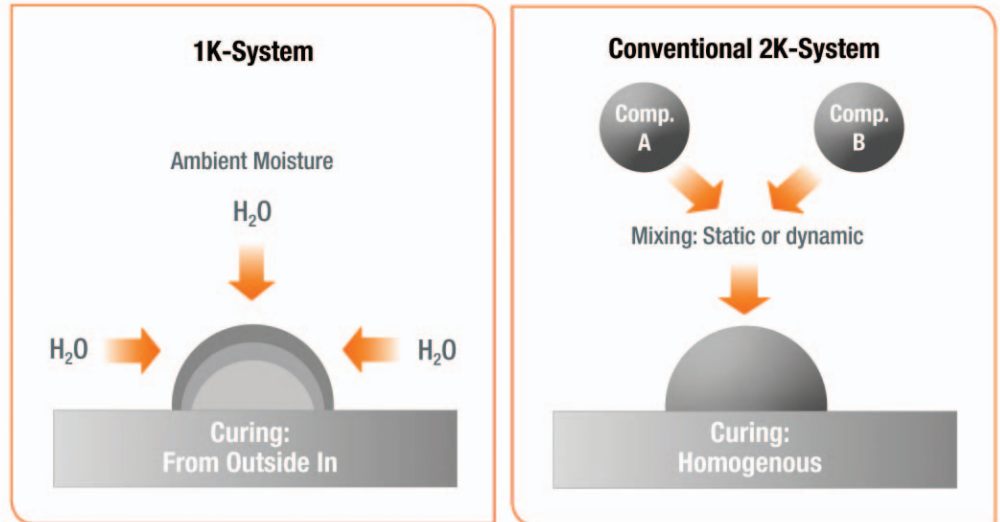

### 1K Silane Modified Polymers (SMP) or Modified Silane Polymer (MSP)

These products exhibit high resiliency while maintaining high tensile strength and good adhesion to many substrates – without the use of a primer – and may be substituted in for polyurethanes or silicones, as needed. They are suitable for use in:

- Applications with high movement, high impact, dissimilar substrates or those exposed to heating and cooling cycles, damp conditions or UV light
- Processes where the sealant must be applied prior to painting. This is a key feature that sets them apart from silicones and polyurethanes.

It is prudent to evaluate sealant materials for compatibility with substrates, paint, and your processes. Poor cleaning methods may leave a residue that can result in a paint defect. For example, a residual solvent can inhibit the cure and interfere with intersurface adhesion of the sealer to paint. Therefore, paint, sealers, solvents and cleaning chemicals must be tested for compatibility before use in a paint shop. Further, these materials need to be controlled within the facility. Impacted plant groups – i.e., Employees-Union, Quality Assurance, and Environmental, Health, and Safety should be involved in the selection and validation of materials and be informed of the potential consequences of untested change orders.





## Test and Validation

A strong test and validation plan is necessary to ensure that specified adhesives and sealants' durability and service life requirements are met. The plan should be developed with your materials suppliers and executed in conditions approximating production conditions as closely as possible (see the Testing & Specifications section on page 34 for more test information). Key test parameters may include:

1. Adhesion to substrates – it is always important to replicate the production material condition and cure as closely as possible.
  - a. Lap Shear – ASTM D1002
  - b. Peel – T-peel ASTM D1876, Cross peel ASTM D897
2. Paint adhesion to the sealant
  - a. Cross-hatch adhesion – ASTM D3359
  - b. Accelerated adhesion – Adhesion of paint/sealant following condensing humidity exposure – ASTM D4585, D2247
  - c. Staining or paint-plasticizer interaction – usually involves weathering methods (refer to OEMs for specific test methods).
  - d. Over/under cure testing at process boundary conditions.
3. Durability tests including but not limited to:
  - a. Heat aging – accelerated heat aging by oven, then measuring adhesion. Cold flexibility or cold impact may also be checked after heat aging.
  - b. Cold flexibility – often bending over a mandrel to evaluate either adhesion to the substrate or paint to the sealant. Cold is usually defined as -40°C (-40°F), albeit this can vary by OEM and intended application.
  - c. Corrosion/humidity aging – evaluate adhesive and sealant performance in a high moisture environment.
  - d. Thermal cycling – evaluate material after cycling through temperature extremes for potential cracking or adhesion loss.

- e. Stone impingement (Gravelometer) – SAE J400 – Usually in cold (-40°C) conditions, the chipping resistance of a surface coating is evaluated in a laboratory procedure designed to simulate the effect of gravel or other media striking exposed paint or coated surfaces of a vehicle in the field. This test is often followed by corrosion or humidity testing to evaluate the toughness of the coating system and to identify any corrosion effects including sacrificial corrosion protection offered by coatings on various types of materials.
  - f. Cold impact – cold dart impact, again usually -40°C (-40°F).
4. Viscosity stability/Storage stability – evaluate viscosity following long-term low heat aging to simulate storage.
  5. Hot/cold strength – Measure adhesion at extreme temperature conditions.
  6. Chemical compatibility with cleaning and painting materials. This is not to evaluate the chemical resistance of the cured materials, though that is a valid concern as well, but rather to assess any pre-cure interactions amongst specified materials, including paint.





## ADHESIVES

### ***Post-Prime – Pre-Topcoat Structural Bonding***

The [ASC OEM Body Shop Adhesive and Sealant Selection Guide](#) is an excellent design, process, and material selection resource – providing practical information for end users relative to structural bonding in body shop applications. Many of those guidelines can be applied to the paint shop, as well. However, in a paint shop application, the metal components have passed through surface preparation, conversion and primer application processes yielding an optimal bonding surface ready for paint. While automotive OEMs tend to be loathe to perform bonding operations in their paint shops, they may require it of tier suppliers. Non-automotive transportation OEMs often prefer the opposite tack using paint operations as an extension of assembly to take advantage of the pristine bonding conditions for key structural assemblies.

*Figure 5: Structural urethane adhesive applied to SMC reinforcements of larger skin parts. These parts are bonded before being sent to the paint shop for finishing. Source: Ashland*



Post-prime assembly operations have a lower process temperature requirement. Typical e-coat bake temperatures are in the range of 175°C (347°F). As previously mentioned, primer-surfacer and topcoat paint bake temperatures typically range from 120°C to 150°C (248-302°F). From an adhesive curing standpoint, 1K (1 part) epoxies usually require over 150°C (302°F), with the caveat that lowering this requirement can be achieved with newer technology. Curing 2K (2 part) epoxies and urethanes can happen at room temperature although some hybrid systems require a bake to fully cure. Most acrylic/ Methyl methacrylate (MMA) systems need no bake; in fact, a quick, hot bake immediately after application can cause damage, although most can handle topcoat bake conditions after the initial cure.

Criteria for material selection includes the point at which the part joins the assembly line: unlike parts added in the paint line, an assembly in the body shop must survive the high bake of the primer operation. For example, a bonded composite assembly processed in the body shop requires a high-temperature resin for the composite and a high-temperature adhesive to survive the bake – a typical selection to meet this requirement is an epoxy adhesive system. However, the same assembly if processed before the topcoat, could use

a lower temperature composite resin, yielding a broader selection range of adhesive systems; for example, urethane or acrylic/MMA adhesives as well as the epoxy adhesive.

Lower temperature resistant materials are attractive because they cost less and can have lower tooling costs. Consequently, lower temperature resistant substrates that can be specified in post-prime processing such as composites and thermoplastics that cannot survive high prime bake systems are cost-effective alternatives to other material selections.

Common composite applications include hoods/lids, doors, roofs, grill opening panels, external sun visors, and aerodynamic panels. Common thermoplastic applications include lower aero/ground effect panels, and bumper covers. All of these applications can include bonded reinforcements or other features. And some can be bonded directly to the body. See Figure 5 for an example of a composite bonding application.

Typical assembly operations would include heat bonding fixtures for urethane and epoxy systems as well as ambient fixture bonding for acrylic/MMA systems, and fastener-assisted fixtures required to stabilize the joint as the adhesive cures and undergoes further processing.



## OTHER MATERIALS AND APPLICATIONS

Paint Shop and post paint applications share common materials, processes, and suppliers with adhesives and sealants. Materials that are used for acoustic enhancement, structural reinforcement or corrosion-resistance have common properties. Filling cavities and pillars is an application that when performed in the body shop uses preformed parts, expandable sealants and adhesives, often

on metal or plastic carriers. Allowing the body to pass through cleaning, pretreatment and priming operations without significantly obstructing the cavity. The parts then expand and cure in the prime bake oven. Other applications use heat-cured epoxy adhesives with fiberglass cloth or metal reinforcement.

Preformed parts are replaced by liquid materials in the paint or trim shops. These materials are injected into cavities to fill and bond; after allowing the cavities to be thoroughly processed (cleaned and primed) without interference or the possible contamination of parts falling off in the paint system. Figures 6a, 6b and 7 show filled section demonstrations.

Typical applications include low-density,

*Figure 6a: Cutaway lower pillar section showing adequate foam fill. Source: Sika*



*Figure 6b: Foam injection demonstration of filling a C pillar with a clear skin to see fill. Source: Dow Automotive*

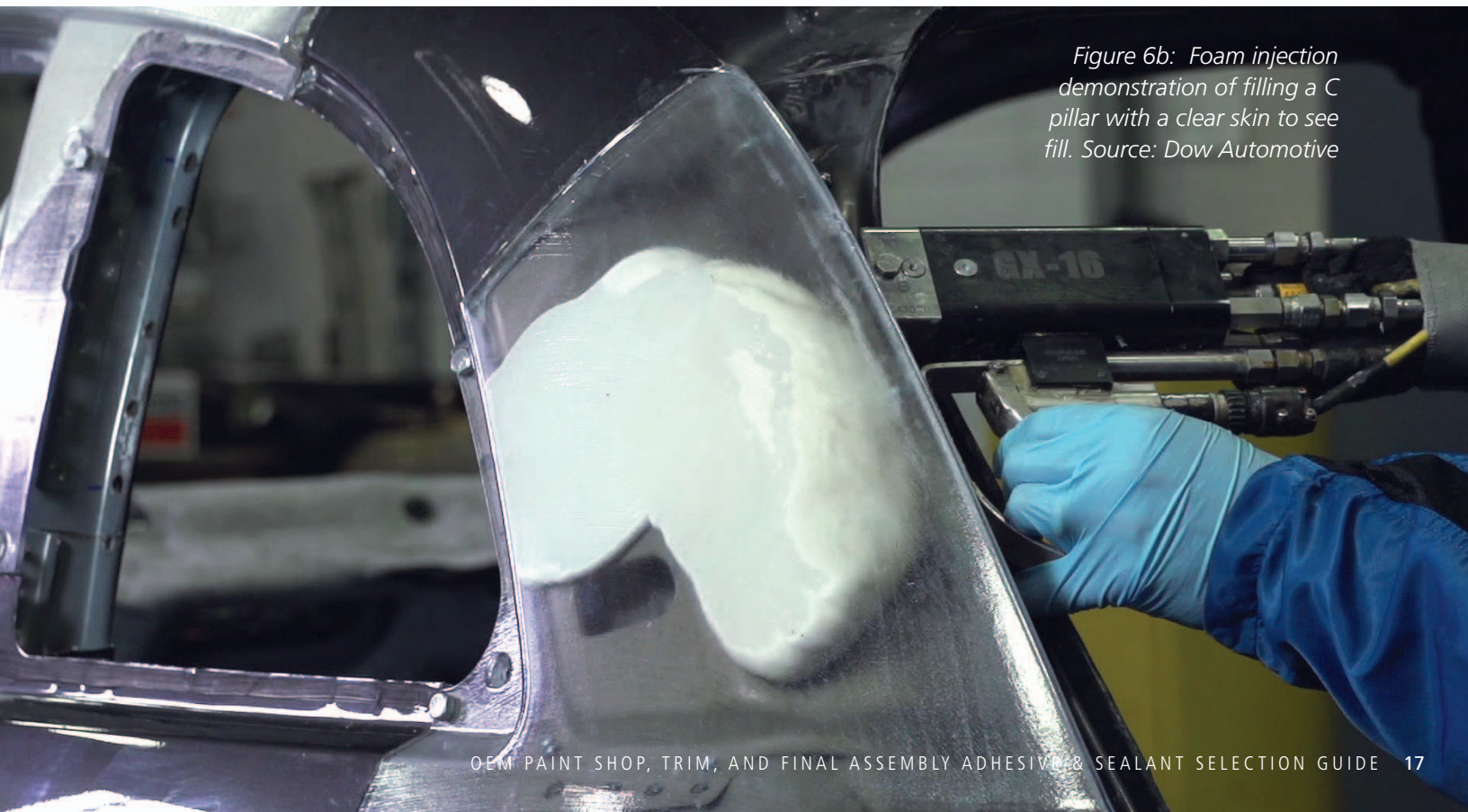

**Beltline**

The beltline is defined as the bottom line of the glass around the vehicle. The location of the beltline drives material selection above and below: moisture exposure below the beltline is acceptable in normal operation, while the area above the beltline should remain dry to prevent deterioration and/or odor caused by moisture retention.

high expansion, impingement-mix urethane foams to manage air and sound intrusion. These materials provide a low cost, highly reliable filling solution to seal large cavities. When structure is required, high density, static mixed, structural foams – epoxies or urethanes – are used to reinforce structures from collapse to improve crashworthiness and roof strength. These materials prevent posts/pillars/channels from collapsing easily (think of crushing a beverage can) by retaining their wall structure and improving the dynamic strength of the body.

The material trend in this space follows many others in automotive for lower weight materials, including the low-density acoustic foam and the high-density structural foam, which is still lighter than other solutions. Certain renewable materials for low-density foam are trending, including soy-based materials. Likewise, low-density foams can be an open or closed cell for improved acoustic performance or better water resistance. Open cell foams allow sound to pass through and be absorbed – while closed-cell may only reflect sound (which can be detrimental to acoustic performance). Of course, open-cell foams readily absorb water too, so if the application is below the beltline,

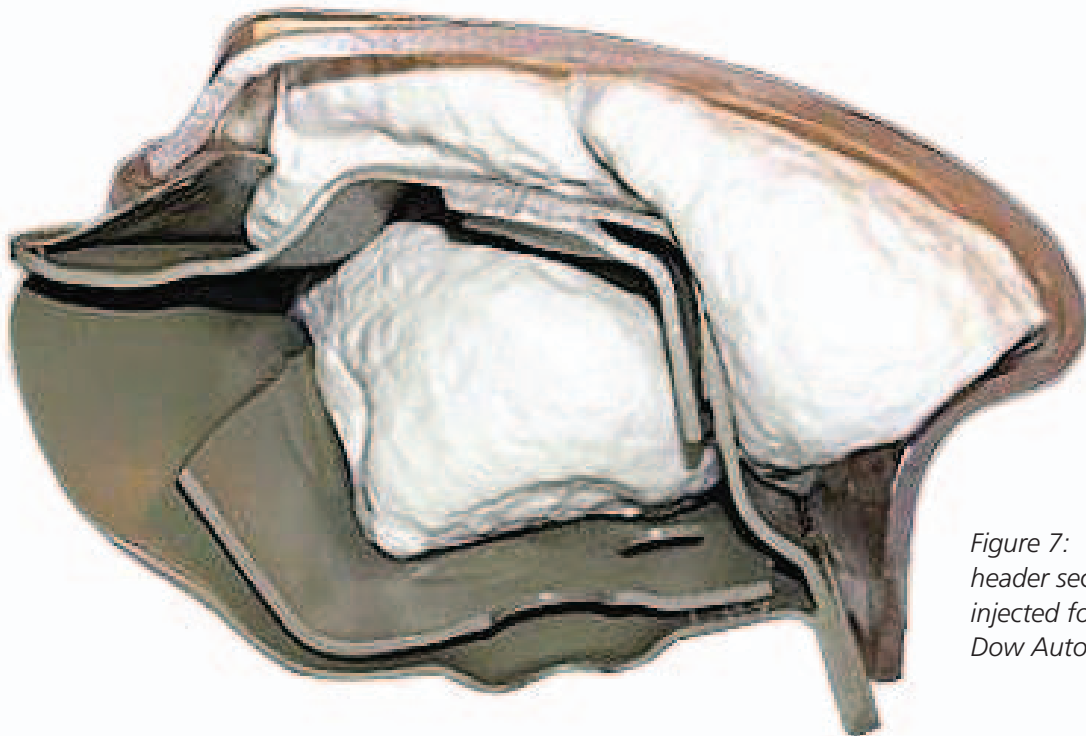

Figure 7: Cut away of header section filled with injected foam. Source: Dow Automotive



closed-cell foam may be specified. Critical acoustic applications will still be open cell or fiber even below the beltline. Common applications include flooring systems and dash insulators.

Underbody and acoustic coatings — often plastisols, butyls, acrylics or similarly compounded materials — are used either for acoustics or stone impingement. Typically, a plastisol will be sprayed as a coating to an underbody and the wheel-well areas. The material may cure as a solid film or have a blowing agent to foam the film during cure. The foam will help absorb road noise and dampen impact. A solid film will better protect the underbody from stone impingement and improve corrosion performance. A solid film will also dampen impact and structural noise but will not provide acoustic absorption.

Damping materials are elastic solid mass sheets or heavy applied films. They can also consist of multi-layer composite constructions to optimize performance in a given application. For example, constrained layer damping materials – alternating damping elastomers (usually butyl rubber) with stiffening constrained layers (often foils or fiberglass with epoxy) to adjust acoustics as needed.

Acoustic quality is as important as the volume of sound. Stiffening raises a panel's acoustic pitch while damping lowers it. Generally, a higher pitch is not desirable and sounds "cheap." A lower pitch sounds solid with better quality. For example, a door closing with a tinny sound is less desirable

## IN-DEPTH

**NVH – Noise, Vibration, Harshness**

*The topic of NVH (noise, vibration and harshness) is a complex topic that is integral to the whole vehicle design. Adhesives and sealants are key components of NVH solutions.*

- Adhesives stiffen body structures and bond rubber mounts for isolation.
- Sealants close off noise leaks.
- Acoustic materials are bonded or laminated to improve effectiveness and are made to abate either airborne or structural noise.

*Absorptive materials are foams made to allow airborne noise to enter and be trapped in the cell structure. Headliners are a common example: noise passes through the textile covering to the foam and fiber behind it where it is trapped, preventing "bounce back."*

*Damping materials are usually solid, high mass materials that either completely block sound or dampen the transmission of structural sound. Mass loaded sheets bonded to floor or body skins are examples. These materials are often mixed and matched for an enhanced effect, such as flooring systems and dash insulators utilizing a mass damper that is isolated by an absorptive foam or fiber.*

than a low, solid thud. Stiffening a panel can cause higher pitches while damping lowers the pitch. Properly combining the two (constrained layer damping) can fix stiffness issues for optimal acoustics.

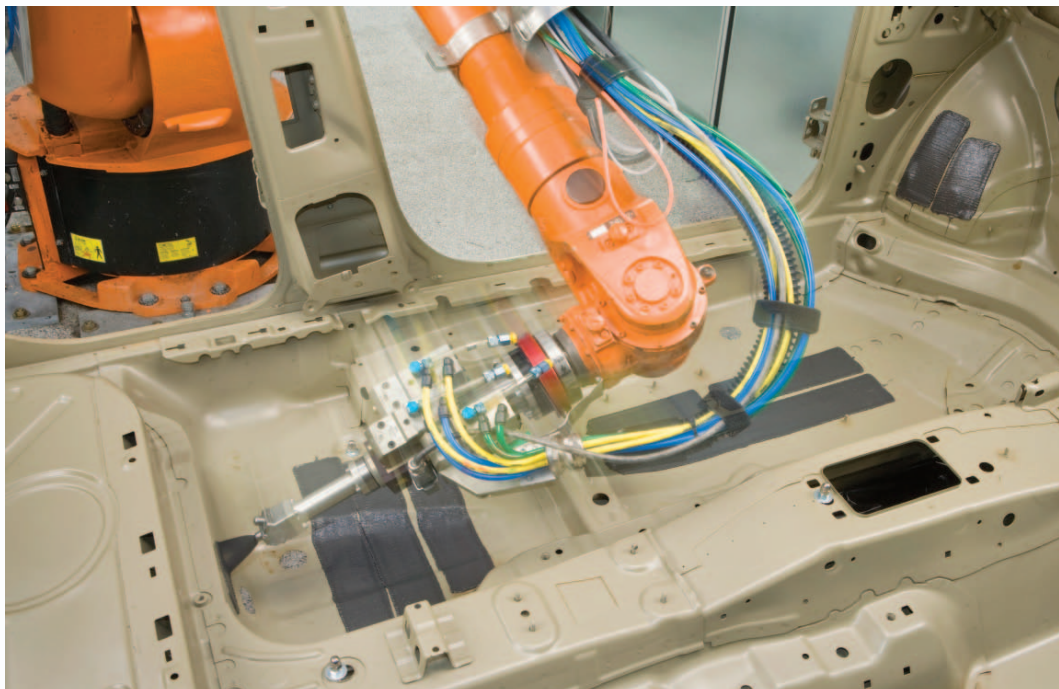

The automotive segment avoids the additional mass whenever possible, yet it is necessary when other acoustic abatements are not satisfactory. Other vehicles that do not have the weight constraints of automotive OEMs are amenable to using mass dampers but only on an “as required” basis to avoid adding unnecessary costs. Mass dampers are die-cut hot-melt sheets; or solid sheets that are bonded with a PSA. Liquid applied sound deadeners (LASDs) are common replacements for solid die-cut sheets where appropriate, examples can be seen in Figures 8 and 9. The paint shop is used for these mass damping processes due to the clean, ready-to-bond surface and the available bake ovens. Whereas the trim line is typically used for PSA or self-curing applications (LASDs).

These materials are also used to cover and close holes in the body construction. These may have been for pretreat-prime drainage or fixturing holes in body construction. Once assembled and primed they are no longer needed. If the holes are covered with thin, light tape, then they become acoustic passages. The mass is usually targeted to meet the mass of the surrounding sheet metal and will often use metal to bridge the gap with an adhesive-sealant to fill and bond.

*Figure 8: Liquid-applied sound deadener (LASD) robotically applied to the body in the paint shop. This replaces die-cut sheets that would be traditionally melt-bonded through the bake cycle. Source: Henkel*

*Figure 9: Another view of LASD applied to the body in the paint shop. Source: Henkel*



## Body Trim and Final Assembly

Processes such as body trim and final assembly that follow body painting use a low volume of liquid adhesives and sealers (as opposed to the body and paint shops), with one significant exception – glass bonding, a process that uses a high volume of adhesives. Pressure sensitive adhesives (PSA) including PSA tapes that are often pre-applied to parts and assemblies before entering the assembly plant are commonly used. Many of the materials for NVH (noise-vibration-harshness), structural enhancement and corrosion protection (covered in the “Other Materials” section of the Paint Shop Guide) can be applied after painting – provided that heat is not required for activation/cure. Parts that simply require attachment without structural function such as badging, films and labels use PSAs as well.





## PRESSURE SENSITIVE ADHESIVES

Let's start with a brief discussion of PSAs. In transportation applications, PSAs are generally rubber-based, acrylic or a specialty material such as silicone. Most permanent PSA applications in transportation are acrylics due to their heat, weather and chemical resistance, as well as their excellent adhesion to a wide variety of substrates. Since acrylic chemistry is also versatile allowing for a broad range of tack, peel and shear strength, and performance over a wide temperature range, acrylic PSAs can be designed to be repositionable or to have very aggressive tack. Recent advances include a dual-stage PSA that undergoes a second cure, converting it to a quasi-structural bond. Rubber adhesives are commonly used in

applications that are temporary or for fixture positioning during assembly. Of course, this is not a hard and fast rule, so exceptions apply. Typical rubber adhesives use one of several polymers: natural rubber (NR – isoprene-based), styrene-butadiene (SBR – Buna S), styrenic block copolymers (SBC), isobutylene-isoprene (IIR – butyl rubber - Buna), chloroprene (CR – Neoprene) and acrylonitrile-butadiene (NBR – nitrile – Buna N). Rubber PSAs can be compounded for very high tack and high strength and, when combined with antioxidants and UV absorbers, can have good durability. These adhesives are used in applications that are temporary (or for fixturing during assembly) due to their aggressiveness.







Figure 10: Door inner water shield bonded with a hot melt pre-applied PSA. The hot melt is robotically applied to die-cut plastic sheets to bond and seal the sheet before the door inner trim panel is assembled to the door.



Figure 11: Door inner trim panel installed after moisture barrier.



Figure 12: Visor warning label with car seat cautions. Source: Avery Dennison



Figure 13: Wire harness label used for work-in-progress (WIP) tracking and identification. Source: Avery Dennison



Figure 14: Door jam (B pillar) label with vehicle manufacturing details and VIN number. Source: Avery Dennison

A far from complete list of potential PSA applications include:

1. Door water shields – Figures 10 and 11.
2. Paint masking, fine line tape
3. Fixturing tape (e.g., retain glass for bonding)
4. Protective films for assembly
5. Transportation films
6. Labels – Figures 12, 13, and 14
7. Trim assembly
8. Badging
9. Moldings – Figures 15 and 16 (next page)
10. Body closure seals
11. Hook and loop fasteners
12. Route and clip fasteners
13. Body gap seals
14. Lighting seals
15. Body locators and drain tape covers
16. Mass dampers
17. Insulation – thermal and acoustic
18. Heat shields
19. Graphics
20. Paint protection films
21. Paint replacement colored films





Figure 15: Moldings bonded with PSA. Source: 3M

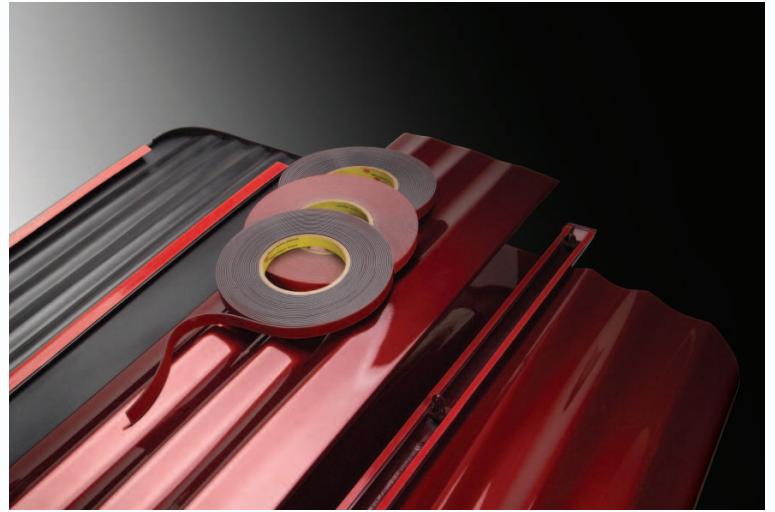

Figure 16: Various moldings bonded with PSA. Source: 3M





# ADHESIVES.ORG SEALANTS.ORG

## Driving Innovation for Manufacturers



- Stronger, Stiffer, Lighter, and Better Performing Products
- Quieter, More Comfortable, and Safer Products
- Streamlined Assembly
- More Fuel Efficient Vehicles
- Solutions for Difficult Joining Problems, Including Multi-Material Joining
- More Aesthetically Pleasing Designs

Visit our industry portal to learn how to put the power of adhesives and sealants to work for your products...

### Tools & Resources

Technology & vendor selectors, bonding questionnaire, calculators

### Instructional Videos

Application videos and tutorials

### Newsroom

Latest news, presentations, white papers, case studies

### Online Training

Webinars on adhesive & sealant technologies, critical regulatory information, benefits, trends

### Ask an Expert

Access and dialogue with industry experts about YOUR specific needs

### White Papers

Technical papers and selection guides for specific markets and applications

## Download WHITE PAPERS on Adhesives & Sealants in Transportation including:

- Joining Methods in Land Transportation
- Adhesives & Sealants in Light Duty Vehicles
- Adhesives & Sealants in Heavy Duty Trucks & Buses

### Topics covered include:

- Common joining methods
- Joining considerations and reliability factors
- Design and materials selection, including dissimilar materials considerations
- Fuel economy and safety factors
- Weight reduction techniques
- Markets, growth, drivers, key applications
- Regulatory requirements



LEARN MORE AT:

[www.adhesives.org/engineers](http://www.adhesives.org/engineers)



### Corrosion

*Corrosion performance is another complex topic that can be improved by proper design, materials, coatings, and process – cleaning, pretreatment and painting. Water management is a critical design/process feature: holes added to the body to allow process fluids to drain; fixture holes for body assembly are filled to seal in air and seal out noise. But, water brought in by the user or let in due to operation needs must have holes to escape. Standing water can accelerate corrosion.*

*Adhesives and sealants play a critical role in moisture control: they prevent the introduction of moisture and salt while filling joints. For mixed material vehicle construction, structural adhesives provide an effective isolation barrier to manage galvanic corrosion, for example, using structural adhesives with self-piercing rivets (SPR). The adhesive effectively seals water from the joints as well as around the applied SPR, unlike a thermal joining method (spot welding) which burns the adhesive away at the application area.*

## CORROSION CONTROL

Corrosion control products are not always sealant materials but are closely related. These applications may include sealants applied to joints, which weren't sealed or coated in earlier operations, using air/moisture curing technology – usually, urethanes or silane modified polymers. Silicones are generally not used, as transfer to a painted surface can cause considerable pain if a repaint is required.

Coatings also use air curing technology such as water-based acrylics or butyls and reactive systems such as urethanes or polyureas. Hot applied coatings can still be found including waxes, hot melts, and hot-applied reactives. Applications include underbody coating, wheel wells, closures, and chassis parts connected to the body.





## BODY TRIM ASSEMBLY

The trim shop is likely the largest volume user of adhesives in automotive assembly operations albeit little is used in the OEM assembly operation. Transportation trim shops are generally limited to PSA applications (see above) and a few hot melt assemblies. The common application is the headliner assembly using reactive hot melts (urethanes) or semi-pressure

sensitive (rubber based) hot melts for trim and flooring applications. Non-automotive transportation operations may use more adhesives by volume as some of the trim assembly work may be performed offline at the OEM, with the caveat that most large volume OEMs have outsourced this work to their trim suppliers.

## GLAZING - GLASS BONDING

Direct bonded glass systems are major structural components of the automotive body system. They provide significant body stiffness and structural support during crash and rollover events. Commonly, front and back lights are bonded, other glass systems such as fixed side or roof glass may also be bonded but may use static seals. Non-automotive-CV applications are bonded and use rubber seals (probably dependent on the vintage of the base body structure design). Glass usage is expected to continue to grow at significant rates in tandem with the use of glass as a design feature.

The glass is bonded using an elastomer adhesive – typically urethanes, with a percentage of SMP and others in use. The bond gap is significantly larger than the other, stiffer structural applications. A high strength structural epoxy is usually targeted at a bond gap of 0.25 mm (0.01 inch) for a strong, stiff bond.

### IN-DEPTH

#### **Glazing**

*Two general types of glass are used in transportation applications: the front windshield is laminated, annealed glass. Heat strengthened glass can be used in laminated applications to reduce glass weight and improve strength. During the glass forming process, a black, ceramic paint is silk screen printed onto the inner (bonding side) of the glass. The ceramic frit is fired onto the glass through the forming ovens. The frit cosmetically covers the bonding surface while providing additional ultraviolet protection and a good bonding surface. A polymer, polyvinyl butyral (PVB), film is laminated between the two layers of glass bonding them together.*

*Side, rear, and roof glass is usually tempered, single pane glass. Laminated glass may be used in some vehicles for improved acoustics and safety. A ceramic frit is similarly applied and fired onto the glass.*

Plastic/composite applications will be around 1.0 – 2.0 mm (0.04 – 0.08 inch) to accommodate more material variance and to provide more energy absorption in the bond line. Glass bonding systems usually target 5 mm (0.2 inch) bond gaps to manage the large difference in thermal expansion of conventional steel body and glass. It also provides damping for hard structural inputs for the vehicle. Applied adhesive beads are shaped into a triangle that ranges from 8-12 mm (0.3 – 0.5 inch) base and 10-15 mm (0.4 – 0.6 inch) high. An automated application is highly recommended for consistency, sealing, and repeatability. Transportation OEMs apply the adhesive to the glass, which works well with automation, while most replacement

technicians will apply to the body.

The body flange is usually a spot-welded joint that has been primed and painted. Adhesives can bond directly to most automotive finishes. Some operations will still prime the paint to ensure a clean, ready to bond surface as this will correct for any variations in the surface due to handling and dirt. The glass will be prepared for bonding by cleaning and priming. Priming can be done at the OEM or the glass supplier. The primer may be a one- or two-pass system. Commonly an organo-silane is used to link to the glass surface. A black urethane paint may be incorporated to provide additional UV protection and to aid adhesion. An alternate system only uses the organo-silane activator to the frit and relies on the frit for UV protection (the adhesive may be UV stabilized).

Primerless-to-paint is becoming the dominant selection albeit some practitioners protest “if it’s not broken, don’t fix it,” and still require a primer before painting. Newer paint technology is going to lower surface energy clearcoats making bonding more difficult. The low surface energy paint is micro-scratch-resistant, more chemically resistant, with improved overall aesthetics. The elastomer adhesive is trending to a higher modulus variant to improve further body stiffness taking full advantage of the very stiff glass panels. Adhesives are being compounded for lower conductivity due to the increase in electronics and glass heating systems.

## IN-DEPTH

### **Glazing Trends**

*Trends in automotive glass systems include improved acoustics, and light-weighting of both the glass and the adhesive. Press bent glass is becoming more common for greater styling flexibility (e.g., deeper draws) and quality control, given that tighter tolerances are often needed for encapsulated moldings, which are molded directly onto the glass. This changes the frit chemistry and bonding performance. Frit trends are to increase acid resistance and lower firing temperatures. Each new frit causes bonding validation of the current systems. One change that negates this is moving the frit to the inner laminate surface so the bonding is limited to the glass surface.*



The glass with the adhesive applied and body prepared, is positioned on the body and set in place. "Locating" design features or temporary fixtures are used to locate and hold the glass while the adhesive cures. Body tape is a temporary reinforcement while the body moves down the production line; however, concern it may damage soft paint has curtailed body tape's use. See Figure 17 for an example of an automated adhesive dispensing system.

*Figure 17: Automated windshield adhesive dispensing system. The windshield is prepared and primed earlier in the process. The robot applies a continuous bead of adhesive to the perimeter of the glass. This ensures uniform application and a positive seal when installed. Source: Dow Automotive*





## Transportation - Non-Automotive and Repair

Many glazing systems have converted to a bonded system, but rubber gaskets are still the most common mounting system outside of automotive. Higher volume body designs that have been updated in the past couple of decades will have used the structure of the glass to enhance body strength rather than relying on the design to hold the glass without structural benefit. For the most part, older base designs still use rubber gaskets. The gaskets will use butyl, SMP or urethane sealants to help seal the glass and the body. The use of butyl sealant coated foam (BCF) is common to seal glass. The PVB laminate will absorb trapped

water, fogging the windshield, unless it is properly drained and sealed to prevent moisture retention.

Polycarbonate glazing has seen significant penetration in applications in agriculture, construction, and severe-service truck and bus. Excellent impact resistance is a major factor in the design case. These may be bonded or gasketed in their design.

Repair systems may use a primerless-to-glass adhesive system or a primer system with an adhesive. Meeting OEM requirements while providing fast, safe driveaway times has been challenging. See Figure 18 for an example of a manually applied glass adhesive.



*Figure 18: Manual windshield adhesive dispense. Common application method in CV plants and aftermarket repair systems.*



## Glass Bonding Test and Validation

A strong [test and validation plan](#) is necessary to ensure good performance and long life. The plan should be developed with your materials suppliers and executed in conditions approximating production conditions as closely as possible (see [ASC OEM Body Shop Adhesive and Sealant Selection Guide](#), the Paint Shop section, and [Adhesives.org](#) for more test information).

Monitoring material variations that may significantly impact glass bonding is a critical step. These include variations in frit paint chemistry and processing. Frit paint will vary by supplier and type of glass processed, and both can be important to adhesive performance. Paint systems also

affect adhesion whether a primer is used or not. Adhesives usually bond to the clearcoat in standard base coat—clearcoat automotive systems. Mono-coat urethanes and acrylics still exist in some applications, although these can introduce surface variations by color. UV exposure before bonding can compromise bond integrity because UV accelerates clearcoat cure, which, in turn, can degrade the molecular-level bond sites that are available to the adhesive on the paint. Moving the substrate or product to the outdoors before bonding commonly leads to UV exposure. Other mitigating factors include bake and repair history and age, including down times and plant shutdowns.

*Key test parameters may include:*

1. Adhesion to substrates – it is always important to replicate the production material condition and cure as closely as possible.
  - a. Lap Shear – ASTM D1002
  - b. Quick knife – A test method where the sealant is pulled back and a knife fractures the bond trying to evaluate whether the fracture will propagate or maintain adhesion.
  - c. Hot and cold performance
2. Durability tests including but not limited to:
  - a. Heat aging – oven air aging then measuring adhesion.
  - b. Weathering – ultraviolet testing – QUV, Xenon Arc, and South Florida/Arizona are common.
  - c. Corrosion/humidity aging – evaluate the performance of a high moisture environment.
  - d. Thermal cycling – evaluate the material through severe thermal change and look for cracking or adhesion loss.
  - e. Dynamic fatigue or load cycling

# Adhesive and Sealant Joint Design Considerations

Modern adhesives and sealants are remarkable materials that are capable of being used in wide variety of joint configurations. Although there are limitless possibilities of joint configurations, most are variations of lap and butt joints.

The strongest and longest lasting bonds are created when joints are designed with adhesives in mind so that stresses can be managed appropriately. The types of stresses commonly found in adhesive joints include tensile, compressive, shear, peel, and cleavage.

Figure 19: Common adhesive joint configurations.

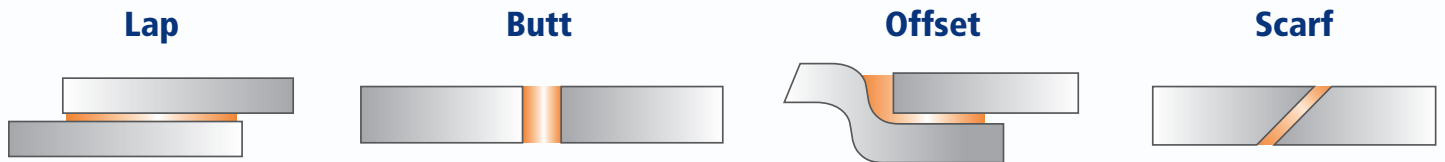

## TENSILE AND COMPRESSIVE STRESSES

Tensile and compressive stresses are applied uniformly across the joint. However, most adhesives perform better in compression than in tension. Adhesive bonds in compression are less likely to fail. Therefore, it is desirable to minimize tensile stresses on the joint and maximize compressive stresses.

Figure 20: Tensile or compressive stresses distribute load evenly across joints.

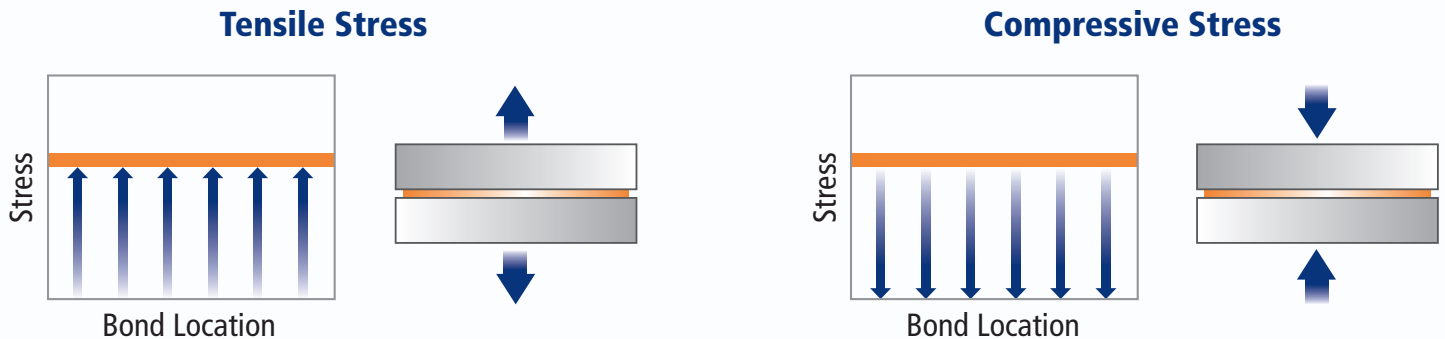



## SHEAR, PEEL, AND CLEAVAGE STRESSES

A shear stress results in two surfaces sliding over each other. Shear stresses are higher at the edges of the joint than in the center. Therefore, it is better to increase the length of shear joints rather than the width, since most of the work is being done at the edge of the bond.

Peel and cleavage stresses result when a flexible or rigid substrate, respectively, is lifted away from the joint at one end. These conditions create a stress concentration at one edge of the bond. Peel creates the highest stress and should be avoided if possible.

Figure 21: Shear, Peel, and Cleavage stresses.

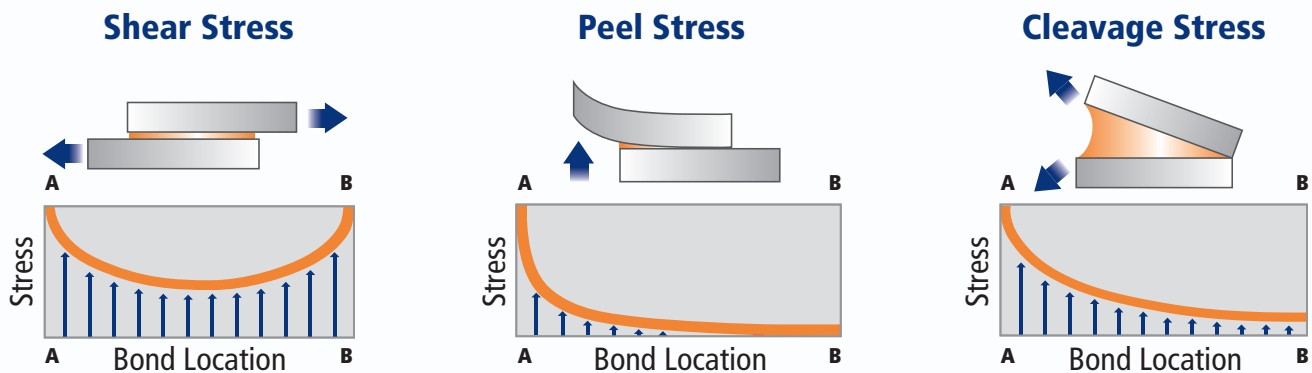

# Auto & Truck OEM Adhesive Testing & Specifications

Automotive and heavy truck OEMs maintain their own protocols for adhesive and sealant testing, evaluation, and approval. As discussed previously in this guide, each application of adhesives and sealants in the OEM paint, trim, and final assembly shops have different requirements, so test protocols often vary

by OEM and application.

Although there is not a single set of standards for adhesive and sealant evaluation in the land transportation industry, there are many similarities in test methods, and some of the more common tests and specification are listed in the table below.

## FAILURE MODE AS A CRITERION IN OEM BODY SHOP ADHESIVE AND SEALANT TESTING

When evaluating adhesives and sealants in shear, peel, and tension testing, it is often not sufficient only to simply meet the criteria for load bearing and elongation. Failure mode is often evaluated just as critically as the strength or elongation of the bond. Many OEM specifications require a cohesive failure or substrate failure. This means that the fracture must occur within the adhesive or the

substrate, rather than at the interface of the adhesive and the substrate. Adhesive failure, which is when the adhesive cleanly pulls away from the substrate, is typically cause for disqualification in OEM specifications. This criterion assures that the interface of the adhesive and substrate is not the “weak link” in the system, and provides confidence that the adhesive will be reliable in service.

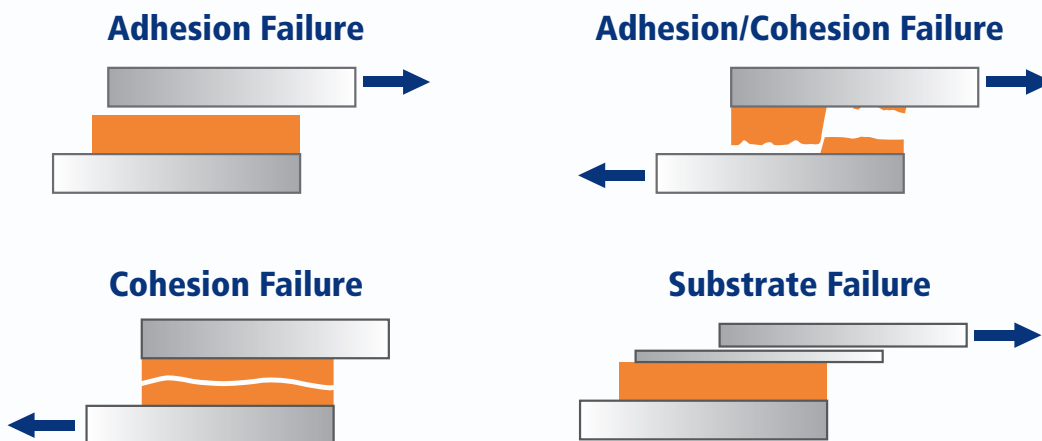
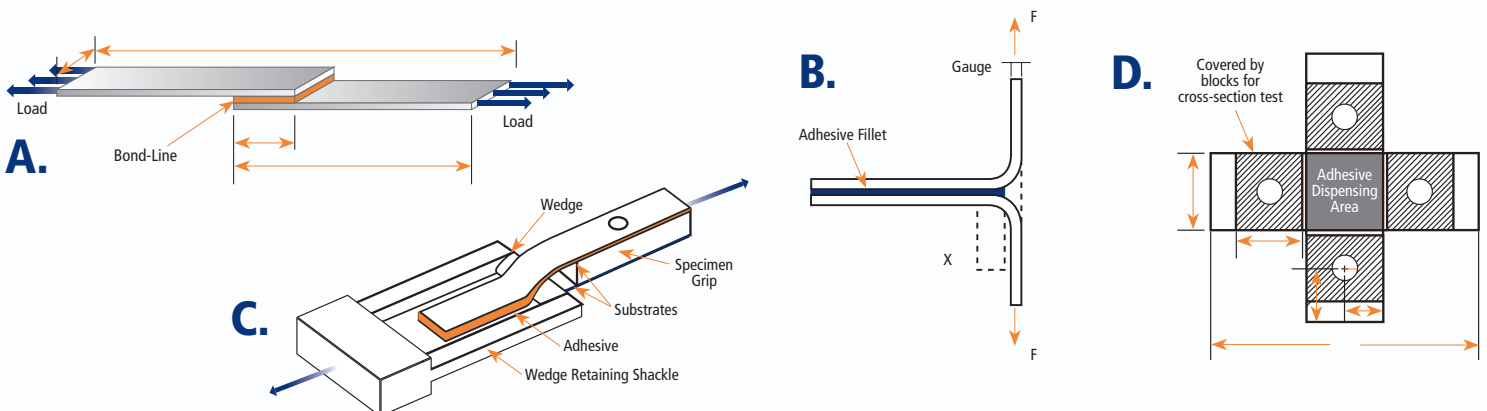

Figure 22: Adhesive failure modes



COMMON AUTOMOTIVE ADHESIVE AND SEALANT TEST STANDARDS

TEST NAME	STANDARDS	DESCRIPTION
<b>Lap shear</b>	ASTM D1002 (metals) ASTM D3163 (plastics) ASTM D5868 (FRP) DIN EN 1465	Determines the shear strength of adhesives when measured on a single lap shear specimen. Standard ASTM sample size is 1" x 4" with an overlap of 1/2" or 1". Tests often conducted at 23C, -40C, and 80C for transportation, and requirements are OEM specific. <b>SEE ILLUSTRATION A</b>
<b>T-Peel</b>	ASTM D1876 ISO 11339	Measures the strength of the adhesive bond in peel. Generally conducted on thin metals that can be bent. Tests may be conducted across a broad range of temperature and environmental conditions. Requirements are OEM specific. <b>SEE ILLUSTRATION B</b>
<b>Impact Wedge Peel</b>	ISO 11343	Measures the resistance to cleavage fracture of structural adhesives at a relatively high strain rate. Often conducted at 23C, -40C, and 80C. Results used as an indicator of toughness and crash resistance. <b>SEE ILLUSTRATION C</b>
<b>Cross Tension (Cross Peel)</b>	ASTM D897 SAE J 1553-1995	Determines the strength of an adhesive bond in tension. Often used for anti-flutter adhesives because the movement of outer panels away from supporting structures creates a tensile load. <b>SEE ILLUSTRATION D</b>
<b>Expansion</b>	SAE J 1918-2002	Method for determination of expansion and water absorption of automotive sealers.
<b>VOC content</b>	OEM specific	Measure VOCs released in plant or that would escape into cabin from cured adhesives.
<b>Weldability</b>	OEM specific	Includes a battery of tests with OEM specific criteria, such as flammability, weld squeeze force, and weld nugget formation.
<b>Salt spray test</b>	ASTM B117 DN50021 OEM specific	Salt spray corrosion condition used as a quick predictor of corrosion resistance. Some OEMs maintain their own standard.
<b>Cyclic Corrosion Test</b>	SAE J2334 VDA 621-415 OEM specific	Cycle of salt spray, temperature, and humidity conditions that is used to simulate long-term environmental exposure in field conditions. Some OEMs maintain their own standard.



## Conclusion

The [ASC OEM Body Shop Adhesive and Sealant Selection Guide](#) starts the body building process in the body shop. This ASC OEM Paint Shop, Trim, and Final Assembly Adhesive and Sealant Selection Guide completes the process to the final vehicle build. There are more OEM adhesive sealant applications in chassis, powertrain, and electrical applications. Tier suppliers' applications are not covered unless there is a significant cross-over to the OEM, but they are rich in adhesive and sealant applications that contribute significantly to vehicle performance. Repair and

aftermarket applications are also a vast application area for adhesives and sealants. For more detailed information, contact your adhesive or sealant supplier, or identify a supplier by using the [ASC Vendor Select Tool](#). The ASC Vendor Select Tool is a quick and efficient way for a user to find an adhesive or sealant chemistry. Go to [www.adhesives.org](http://www.adhesives.org) to find the tool.





## Find the Right Adhesive or Sealant Supplier or Manufacturer for OEM Light Duty Car/Truck Applications

The Adhesive & Sealant Council has a great web-based tool that allows you to search for:

- Adhesives and sealants by market, technology or chemistry type
- Raw materials
- Equipment
- Consulting services.



The online tool guides you through a customized list of parameters in order to deliver a clickable list of suppliers and manufacturers available to meet your needs.

Try it now at [www.adhesives.org/tools](http://www.adhesives.org/tools)

The following ASC Member Manufacturers and Distributors provide adhesives and/or sealants in the light duty car and truck & OEM markets:

*\*Note: Logos are clickable.*

